

(12) INTERNATIONAL APPLICATION PUBLISHED UNDER THE PATENT COOPERATION TREATY (PCT)

(19) World Intellectual Property Organization
International Bureau



(43) International Publication Date
13 February 2003 (13.02.2003)

PCT

(10) International Publication Number
WO 03/012255 A1

- (51) International Patent Classification⁷: E21B 43/10
- (21) International Application Number: PCT/GB02/02886
- (22) International Filing Date: 24 June 2002 (24.06.2002)
- (25) Filing Language: English
- (26) Publication Language: English
- (30) Priority Data:
09/918,002 30 July 2001 (30.07.2001) US
- (71) Applicant (for all designated States except US): WEATHERFORD/LAMB, INC. [US/US]; 515 Post Oak Blvd, Suite 600, Houston, TX 77027 (US).
- (71) Applicant (for IS only): HARDING, Richard, Patrick [GB/GB]; Marks & Clerk, 4220 Nash Court, Oxford Business Park South, Oxford, Oxfordshire OX4 2RU (GB).
- (72) Inventor; and
- (75) Inventor/Applicant (for US only): MACKAY, Alexander, Craig [GB/GB]; 13 Skene Square, Aberdeen, Aberdeenshire AB25 2UU (GB).
- (74) Agents: MARKS & CLERK et al.; 4220 Nash Court, Oxford Business Park South, Oxford, Oxfordshire OX4 2RU (GB).
- (81) Designated States (national): AE, AG, AL, AM, AT, AU, AZ, BA, BB, BG, BR, BY, BZ, CA, CH, CN, CO, CR, CU, CZ, DE, DK, DM, DZ, EC, EE, ES, FI, GB, GD, GE, GH, GM, HR, HU, ID, IL, IN, IS, JP, KE, KG, KP, KR, KZ, LC, LK, LR, LS, LT, LU, LV, MA, MD, MG, MK, MN, MW, MX, MZ, NO, NZ, OM, PH, PL, PT, RO, RU, SD, SF, SG, SI, SK, SL, TJ, TM, TN, TR, TT, TZ, UA, UG, US, UZ, VN, YU, ZA, ZM, ZW.

[Continued on next page]

(54) Title: COMPLETION APPARATUS AND METHODS FOR USE IN WELLBORES

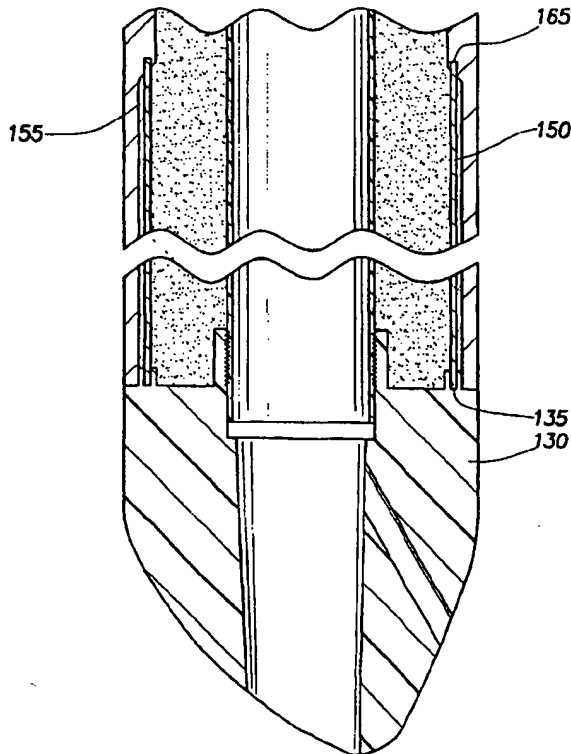

(57) Abstract: An apparatus and methods for preventing the accumulation of unwanted materials in an enlarged inner diameter portion (160) of a casing or housing (110). In one aspect of the invention, a sleeve (150) is disposed in the housing to isolate an annular area (155) defined by the outer surface sleeve and the wall of the enlarged inner diameter portion. The sleeve prevents unwanted materials from being disposed in the annular area. The sleeve can later be expanded into the enlarged inner diameter portion, removed from the wellbore or destroyed. In another aspect of the invention, the sleeve is provided and disposed to cover the enlarged inner diameter portion. By covering the enlarged inner diameter portion, unwanted material is prevented from accumulating at said portion and from interfering with the expansion of the next casing into said portion to form a monobore. The sleeve can be made from materials that are dissolvable, elastically deformable, or retrievable.

BEST AVAILABLE COPY

WO 03/012255 A1



(84) **Designated States (regional):** ARIPO patent (GH, GM, KE, LS, MW, MZ, SD, SL, SZ, TZ, UG, ZM, ZW), Eurasian patent (AM, AZ, BY, KG, KZ, MD, RU, TJ, TM), European patent (AT, BE, CH, CY, DE, DK, ES, FI, FR, GB, GR, IE, IT, LU, MC, NL, PT, SE, TR), OAPI patent (BF, BJ, CF, CG, CI, CM, GA, GN, GQ, GW, ML, MR, NE, SN, TD, TG).

Published:

— with international search report

For two-letter codes and other abbreviations, refer to the "Guidance Notes on Codes and Abbreviations" appearing at the beginning of each regular issue of the PCT Gazette.

COMPLETION APPARATUS AND METHODS FOR ITS USE IN WELLBORES

The present invention provides an apparatus and methods for use in wellbores. More particularly, the invention provides an apparatus and methods for use with a cement shoe assembly having an isolation sleeve for use in monobore wells. Even more particularly, the invention provides a cement shoe assembly with an enlarged inner diameter portion and a sleeve for isolating the enlarged portion from the bore of the cement shoe, thereby facilitating the expansion of a tubular into the enlarged portion after cementing. The invention also provides an isolation sleeve for use with a casing in a monobore well.

In the drilling of a hydrocarbon well, a wellbore is formed using a drill bit that is urged downwardly at a lower end of a drill string. After drilling a predetermined depth, the drill string and bit are removed and the wellbore is lined with a string of tubulars or casing. The casing is subsequently cemented, thereby protecting the formation and preventing the walls of the wellbore from collapsing. The casing also provides a reliable path through which drilling tools, drilling mud, and ultimately, production fluid may travel.

After the wellbore is lined with the initial string of casing, the well is drilled to a new depth. A new string of tubulars or liner is then lowered into the well. The new liner is positioned so that the top of the liner overlaps the bottom of the existing casing. Thereafter, with the liner held in place with a mechanical hanger, the liner is cemented. In cementing a tubular string, a column of cement is pumped into the tubular and forced to the bottom of the wellbore where it flows out and flows upward into an annulus defined by the wellbore and the new string of liner.

In order to facilitate cementing of a tubular string in a well, a cementing apparatus referred to as a cement shoe may be lowered into the wellbore at the bottom of the tubular string to be cemented. The shoe typically includes various components including a tapered nose portion located at the downhole end of the tubular to facilitate

insertion of the shoe into the borehole. Additionally, a check valve constructed and arranged to partially seal the end of the tubular is provided. The check valve prevents entry of well fluid during run-in while permitting cement to subsequently flow outwards. The same valve or another valve or plug typically located in a baffle collar
5 above the cementing apparatus prevents the cement from back flowing into the tubular. Components of the cementing shoe are made of fibreglass, plastic, or other drillable material. Once the cementing is completed, the shoe and any cement remaining in the casing can later be destroyed when the wellbore is drilled to a new depth.

10 Recently, an apparatus has been developed for expanding the diameter of a liner in a wellbore to conform to the larger diameter of a previously run casing string. Figure 1 is an exploded view of an exemplary expansion tool 700. The expansion tool 700 has a body 702 which is hollow and generally tubular with connectors 704 and 706 for
15 connection to other components (not shown) of a downhole assembly. The connectors 704 and 706 are of a reduced diameter compared to the outside diameter of the longitudinally central body part of the tool 700. The central body part has three recesses
20 714 to hold a respective roller 716. Each of the recesses 714 has parallel sides and extends radially from a radially perforated tubular core (not shown) of the tool 700. Each of the mutually identical rollers 716 is somewhat cylindrical and barrelled. Each
25 of the rollers 716 is mounted by means of an axle 718 at each end of the respective roller and the axles are mounted in slidable pistons 720. The rollers are arranged for rotation about a respective rotational axis, which is parallel to the longitudinal axis of the tool 700, and radially offset therefrom at 120-degree mutual circumferential
30 separations around the central body. The axles 718 are formed as integral end members of the rollers 716 and the pistons 720 are radially slidable, one piston 720 being slidably sealed within each radially extended recess 714. The inner end of each piston 720 is exposed to the pressure of fluid within the hollow core of the tool 700 by way of the radial perforations in the tubular core. In this manner, pressurized fluid provided from the surface of the well, via a tubular, can actuate the pistons 720 and cause them to
extend outward and to contact the inner wall of a tubular to be expanded. Additionally, at an upper and a lower end of the expansion tool 700 are a plurality of non-compliant

rollers 703 constructed and arranged to initially contact and expand the tubular prior to contact between the tubular and fluid actuated rollers 716. Unlike the compliant, fluid actuated rollers 716, the non-compliant rollers 703 are supported only with bearings and they do not change their radial position with respect to the body portion of the tool 700.

5

Historically, each string of tubulars inserted to line a wellbore has necessarily been smaller in diameter than the string previously inserted. In this respect, the wellbore typically consists of sequential strings of tubulars of an ever-decreasing inner and outer diameter. The ability to expand a tubular *in situ* has led to the idea of monobore wells, wherein through the expansion of entire tubular strings in the wellbore, the wellbore remains at about the same inner diameter throughout its length. The advantages of the monobore well are obvious. The tubulars lining the borehole, and therefore, the possible path for fluid in and out of the well remains consistent regardless of well depth. Additionally, wellbore components and other devices can more easily be run into the well without regard for the restriction of decreasing diameters of the lining encountered on the way to the bottom of the wellbore. One problem with monobore wells relates to the difficulty of expanding one tubular into another when the outer tubular is cemented into the wellbore, preventing the outer diameter from increasing as the inner tubular is expanded into it.

10
15
20

In order to facilitate the assembly of tubular strings to form a monobore, the lower portion of the upper string of tubulars is specifically designed with an enlarged inner diameter in the area that will receive the expanded upper portion of a lower string. To join the tubulars with an expansion means, the upper end of the second string is aligned with the enlarged inner diameter portion of the first string. An expansion tool is used to radially expand the upper end of the second string into the enlarged inner diameter portion to approximately the same inner and outer diameter as the first string. In this manner, the second tubular string is expanded into the first string without an increase in the outer diameter of the first string and without the use of conventional slips.

25
30

In an example of the above-described design, a cement shoe is built into the lower portion of the first string of tubulars. The housing of the shoe has an enlarged inner diameter portion as discussed above. After the cement shoe is used to cement the tubular string in the wellbore, the interior portions of the shoe are drilled out as a new borehole is formed therebelow. Subsequently, a second string of tubulars is run into the new section of borehole, and the upper portion of the second string of tubulars is expanded into the enlarged inner diameter portion of the first string as described herein.

Because of the enlarged inner diameter portion of the first string, subsequent drilling of the cement shoe is usually inadequate to remove some residual material from the lower portion of the string. The material typically remains around the inside wall of the enlarged inner diameter portion because the outer diameter of the drill bit does not reach it. The residual material can interfere with the connection between the upper end of the next string of tubulars and the lower end of the existing string. Additionally, the residual material may extend into the bore and interfere with wellbore components that are run-in into the wellbore.

A need, therefore, exists for an apparatus and method to more efficiently prevent the accumulation of residual material in a tubular prior to connection to another tubular by expansion. There is a further need for a cement shoe that can be used in a tubular string without leaving residual material in an enlarged inner diameter portion of the string. There is a yet a further need for a cement shoe with an enlarged inner diameter portion and a method and apparatus for temporarily isolating the enlarged inner diameter portion from residual material.

In accordance with one aspect of the present invention there is provided an apparatus for isolating an annular area of tubulars comprising:

a tubular housing having a first inner diameter portion and an enlarged inner diameter portion; and

a sleeve disposed in the housing adjacent the enlarged inner diameter portion, the sleeve having an inner diameter substantially the same as the first inner diameter portion.

5 Further aspects and preferred features are set out in claims 2 *et seq.*

The present invention generally provides an apparatus and methods to prevent unwanted materials such as cement from accumulating in a lower portion of a tubular having an enlarged inner diameter portion. A cement shoe assembly is provided at a lower end of
10 a tubular string with a sleeve co-axially disposed therein to cover the enlarged inner diameter portion of the tubing. The sleeve serves to temporarily make the diameter of the tubular uniform and to isolate an annular area between the outside of the sleeve and the inner wall of the casing. A method of preventing accumulation of unwanted materials by disposing a sleeve in the enlarged inner diameter portion and later
15 expanding the sleeve into said portion is provided. In one embodiment the sleeve is dissolvable. In another embodiment, a deformable sleeve with at least one internal ring is provided to cover the enlarged inner diameter portion. In still another embodiment, the sleeve is retrievable from the surface of the well.

20 Some preferred embodiments of the invention will now be described by way of example only and with reference to the accompanying drawings, in which:

Figure 1 is an exploded view of an exemplary expansion tool;

25 Figure 2 is a cross-sectional view of a cement shoe assembly disposed at a lower end of a tubular and having a housing that includes an enlarged inner diameter portion at a lower end;

30 Figure 3 is an enlarged view of the enlarged inner diameter portion of the cement shoe assembly;

Figure 4 is a section view showing the tubular and cement shoe housing cemented in a wellbore and a second tubular partially expanded into the enlarged inner diameter portion;

- 5 Figure 5 is a section view showing an upper portion of a second tubular completely expanded into the enlarged inner diameter portion;

Figure 6 is a top section view showing a temporarily expanded piece of patch casing coaxially disposed in the cement shoe housing;

10

Figure 7 illustrates the patch casing in a collapsed position; and

Figure 8 is a section view of the patch casing disposed in the enlarged inner diameter portion.

15

Figure 2 is a cross-sectional view of a cement shoe assembly 100 disposed at a lower end of a tubular 101 and having a housing 110 that includes an enlarged inner diameter portion 160 at a lower end. The assembly 100 is typically disposed at a lower end of a string of tubulars that is run into a well and cemented. The cement isolates the wellbore from the formation therearound and prevents the wellbore from collapsing. The assembly 100 is preferably connected to a tubular 101 by a threaded connection 102 formed therebetween. The cement shoe assembly 100 includes a drillable shoe portion 120 disposed within the housing 110. The drillable shoe portion 120 includes a longitudinal bore 123 extending through the centre of the cement shoe assembly 100 and provides a fluid path for the cement. The bore 123 communicates with the tubular 101 through a biased, one way valve 150 disposed at the upper end of the bore 123. The valve 150 permits fluid to enter the assembly 100 but prevents well fluids from passing from the wellbore and up into the tubular 101.

- 25
- 30 Adjacent valve 150, an annular area 121 defined between the bore 123 and the housing 110 is filled with concrete to stabilize the bore 123. Lining the bore 123 between the

valve 150 and a conical nose portion 130 is a tubular 131. The conical nose portion 130 serves to facilitate the insertion of the assembly 100 into the wellbore. Adjacent the tubular 131, an annular area 132 between the cement shoe tubular and the housing 110 is filled with sand 122 or some other aggregate.

5

The housing 110 of the cement shoe assembly 100 includes an enlarged inner diameter portion 160 at a lower end. The enlarged inner diameter portion 160 has an inner diameter which is greater than the inner diameter of the upper section of the housing 110 and of the tubular 101 thereabove. The enlarged inner diameter portion 160 is configured to receive the top portion of a lower string of tubulars 200 (Figure 4).

10

A sleeve 150 is co-axially disposed in the housing 110 and covers the enlarged inner diameter portion 160 to isolate the annular area formed between the inner surface of the enlarged inner diameter portion 16 and the outer surface of the sleeve 150. With the sleeve 150 in place, the inner diameter of the housing 110 is constant and is substantially the same diameter as the tubular 101 thereabove. The constant inner diameter ensures that the cement shoe material is removed as a drill bit passes through the housing 110. The sleeve 150 may be assembled with the cement shoe assembly 100 prior to run-in or the sleeve 150 may be installed downhole with a run-in tool.

15

20

Figure 3 is an enlarged view of the enlarged inner diameter portion 160 of the cement shoe assembly 100. The sleeve 150 is coupled to the housing 110. The enlarged inner diameter portion 160 of the housing 110 has a recess 165 on its upper most end. The recess 165 is constructed to receive an upper end of the sleeve 150. At the top surface of the conical nose portion 130, a second recess 135 is provided to receive a lower end of the sleeve 150. The sleeve 150 may be frictionally attached or attached by a coupling means to the housing 110. The coupling means may be a rivet, screw, glue or other connector that can hold the sleeve 150 in place. The sleeve 150 is also shown forming the annular area 155 with the housing 110.

25

30

In an alternative embodiment, the sleeve 150 may be used to temporarily seal the annulus 155. The sleeve at its lower end has a flange (not shown) that is bent towards enlarged inner diameter portion 160, thereby forming a seal. The seal may have an aperture therein to allow the annular area 155 to equalize pressure as the cement shoe assembly 100 is run into the wellbore. Additionally, the annular area 155 may be filled with a fluid to prevent unwanted materials from accumulating in the annular area 155. The fluid may be a polymer, gel, foam, oil, or other fluid that is displaceable from the annular area 155 when the sleeve 150 is expanded into the enlarged inner diameter portion 160. The annular area 155 is filled with the fluid at the surface during assembly of the sleeve 150 with the housing 110.

In the cementing operation, the cement shoe assembly 100 is inserted into the wellbore on a string of tubulars. Thereafter, cement is injected and exits the bottom of the assembly 100. The cement is then forced up an annular area formed between the outer surface of the assembly 100 and the formation therearound by a column of fluid. The cement is then allowed to cure. With the addition of the sleeve 150, the enlarged inner diameter portion 160 has essentially the same inner diameter as the housing 110 and the tubular string. Subsequently, a drilling tool is run into the wellbore inside of the tubular 101 and the drillable shoe portion 120 and conical nose portion 130 are drilled up and destroyed, leaving only the housing 110 and the sleeve 150. The sleeve 150 is not destroyed because the outer diameter of the drill bit is slightly smaller than the inner diameter of the sleeve 150. Because the sleeve 150 is in place, the drill bit is able to drill out the cement or other unwanted materials in all sections of the housing 110.

After the shoe portion 120 is drilled out, the housing 110 originally used to house the components of the cement shoe assembly 100, becomes a part of the upper string of a tubulars 210. A new string of tubulars 200 (Figure 4) having a smaller diameter is inserted into the wellbore as in prior art methods. The new string 200 has a smaller outer diameter than the inner diameter of the upper string 210 and the cement housing 110 in order to be insert therethrough the upper string 210. Because the upper portion of the housing 110 is non-expandable, the cement shoe assembly 100 with sleeve 150 of

the present invention would typically only be used at the end of the first string of tubulars inserted into a well. Thereafter, some other means of facilitating a cement job would be employed. In one example, a cement shoe could be "pumped down" a tubular and any potential expansion problems are avoided.

5

Figure 4 is a section view showing the tubular 210 and cement shoe housing 110 cemented in a wellbore and a second tubular 200 partially expanded into the enlarged inner diameter portion. The top of the new string of tubulars 200 is shown aligned with the enlarged inner diameter portion 160 and the sleeve 150. The expansion tool 300 is used to expand the new string of tubulars 200 into the enlarged inner diameter portion 160 of the housing 110 so as to form a monobore and fix the tubulars in a sealing relationship. The expansion tool 300 operates with pressurized fluid supplied through run-in string 306. The expansion tool 300 is shown in an actuated position and is expanding the diameter of the new string of tubulars 200 into the enlarged inner diameter portion 160 of housing 110 along with the sleeve 150. Typically, the expansion tool 300 rotates as the rollers 304 are actuated and the tool 300 is urged upwards in the wellbore. The expansion tool 300 can also be urged downward to expand the new string of tubulars 200. In this manner, the expansion tool 300 can be used to enlarge the diameter of new string of tubulars 200 circumferentially to a uniform size.

10
15
20

When the new string of tubulars 200 is expanded, the sleeve 150 is also expanded into the enlarged inner diameter portion 160. The new string of tubulars 200 and the sleeve 150, when expanded together into the enlarged inner diameter portion 160, will have the same inner diameter as tubular 101 thereabove, thereby forming a monobore. Thus, the sleeve 150 becomes *seamlessly* "sandwiched" between the new tubular 200 and the enlarged inner diameter portion 160 of the housing 110. While the upper portion of the housing 110 is not expandable, subsequent tubular strings will be of an outer diameter making it possible for the strings to be inserted through the housing and subsequently expanded to a greater diameter.

25
30

Figure 5 is a section view showing an upper portion of a second tubular 200 completely expanded into the enlarged inner diameter portion 160. The Figure shows the relative position of the new tubular 200 and the sleeve 150 after being expanded by the expansion tool 300 into the enlarged inner diameter portion 160. By expanding the new tubular 200 and the sleeve 150 into the enlarged inner diameter portion 160 of housing 110, the inner diameter of new tubular 200 is aligned with the enlarged inner diameter portion of the housing 110.

In an alternative embodiment, the sleeve 150 may be manufactured from a dissolvable material such as aluminium, zinc, magnesium, or composite material such as carbon fibre. The dissolvable material must be able to withstand the acidic conditions and temperatures found in wellbores and be strong enough to withstand physical abuse by downhole tools and fluids during the cementing process. The dissolvable material is dissolvable by a dissolving fluid such as benzene, acetone, acids such as hydrochloric acid, sulphuric acid, phosphoric acid, hydrofluoric acid, or similar fluid. The dissolving fluid however, must not be strong enough to dissolve the cement, and damage the tubulars or wellbore components.

In another alternative embodiment, a retrievable or drillable piece of patch casing may be used as the sleeve 150. Figure 6 is a top section view showing a temporarily expanded piece of patch casing 500 co-axially disposed in the cement shoe housing 110. The patch casing 500 is a piece of tubing made from elastically deformable materials (Figure 7 shows normal state). The patch casing 500 is sized for the length of the enlarged inner diameter portion 160. The patch casing 500 is made to "deform" into an annular piece of casing by at least one retaining member such as an expandable internal ring 600 (Figure 8). The expandable internal ring 600 is constructed and designed to temporarily expand the patch casing 500 to cover the enlarged inner diameter portion 160 of the housing 110. As shown in Figure 6, no annular area is formed between the patch casing 500 and the enlarged inner diameter portion 160.

In operation, the patch casing 150 is inserted and aligned with the enlarged inner diameter portion 160 during assembly of the cement shoe assembly 100. The internal rings 600 are actuated and expanded, which forces the patch casing 500 to expand and cover the enlarged inner diameter portion 160. The installed patch casing 500 serves the same purpose as the sleeve 150 in previous embodiments and prevents the accumulation of unwanted materials in the enlarged inner diameter portion 160.

After cementing in a wellbore, the internal rings 600 are caused to collapse, thereby allowing the patch casing 500 to resume its original collapsed shape. Figure 7 illustrates the patch casing 500 in a collapsed position. The rings 600 along with the patch casing 600 can be retrieved to the surface using retrieval tools that are well known in the art. Alternatively, the rings 600 can be drilled out causing the patch casing 500 to collapse and to be drilled through by the drill bit.

Figure 8 is a section view of the patch casing 500 disposed at the enlarged inner diameter portion 160. The patch casing 500 is shown in the "deformed" or expanded state. The patch casing 500 is shown having at least two internal rings 600 at each end of the patch casing 500. In the deformed state, the patch casing 500 is able to cover the enlarged inner diameter portion 160 and prevents the accumulation of unwanted materials in annulus 155.

In addition to being used as described above, the sleeve can be used with any casing or tubular that has an enlarged inner diameter portion at an end that requires temporary protection of unwanted materials. Additionally, although the present invention has been described for use in hydrocarbon wells, it is also applicable to geothermal wells, injection wells, or any other type of well.

While the foregoing is directed to embodiments of the present invention, other and further embodiments of the invention may be devised without departing from the basic scope thereof, and the scope thereof is determined by the claims that follow.

CLAIMS:

1. An apparatus for isolating an annular area of tubulars comprising:
a tubular housing having a first inner diameter portion and an enlarged inner
5 diameter portion; and
a sleeve disposed in the housing adjacent the enlarged inner diameter portion,
the sleeve having an inner diameter substantially the same as the first inner diameter
portion.
- 10 2. An apparatus as claimed in claim 1, wherein an annular space is formed between
the sleeve and the enlarged inner diameter portion.
3. An apparatus as claimed in claim 2, wherein the annular space is sealed.
- 15 4. An apparatus as claimed in claim 2 or 3, wherein the annular space is filled with
a void filling substance.
5. An apparatus as claimed in claim 4, wherein the substance is selected from a
group consisting of gel, polymer, foam, oil, and other materials that are displaceable
20 after use.
6. An apparatus as claimed in any preceding claim, wherein the sleeve is made
from a dissolvable material.
- 25 7. An apparatus as claimed in claim 6, wherein the dissolvable material is selected
from the group consisting of aluminium, zinc, magnesium, and composite material such
as carbon fibre.
8. An apparatus as claimed in claim 6 or 7, wherein the dissolvable material is
30 dissolvable by a dissolving fluid selected from a group consisting of benzene, acetone,

acids, such as hydrochloric acid, sulphuric acid, phosphoric acid, hydrofluoric acid and similar fluids.

9. An apparatus as claimed in any of claims 1 to 5, wherein the sleeve is radially
5 expandable.
10. An apparatus as claimed in claim 9, wherein the radially expandable sleeve is a patch casing comprising of an elastically deformable material.
- 10 11. An apparatus as claimed in claim 10, wherein the sleeve is retained in an initial cylindrical shape by at least one retaining member.
12. An apparatus as claimed in claim 11, wherein the retaining member is an internal ring.
15
13. An apparatus as claimed in claim 12, wherein the sleeve and the ring are retrievable to the surface of the well.
14. A cement shoe assembly comprising:
20 an apparatus as claimed in any preceding claim, the housing being for disposal at an end of a tubular string; and
a drillable cement shoe portion disposed in the housing, the cement shoe portion in selective fluid communication with the tubular string.
- 25 15. A method of preventing accumulation of unwanted materials in an annular area in a wellbore comprising:
providing a first string of casing having an enlarged inner diameter portion at an end into a wellbore;
coupling a sleeve to the enlarged inner diameter portion to form the annular
30 area;
disposing a second string of casing into the first string of casing; and

expanding the second string of casing along with the sleeve into the enlarged inner diameter portion.

16. A method of isolating an annular area in a wellbore comprising:
5 providing a first string of casing having an enlarged inner diameter portion at an end into a wellbore;
coupling a sleeve to the enlarged inner diameter portion; and
isolating an annular area formed between the outer surface of the sleeve and the enlarged inner diameter portion.
- 10 17. The method of claim 15 or 16, further comprising sealing the annular area.
18. A method as claimed in claim 15, 16 or 17, further comprising filling the annular area with a void filling substance that is displaceable after use.
- 15 19. A method as claimed in claim 18, wherein the void filling substance is selected from a group consisting of gel, polymer, foam, oil, and other materials that are displaceable after use.
- 20 20. A method as claimed in any of claims 15 to 19, wherein the sleeve is made from a dissolvable material.
21. A method as claimed in claim 20, wherein the dissolvable material is selected from the group consisting of aluminium, zinc, magnesium, and composite material such
25 as carbon fibre.
22. A method as claimed in claim 20 or 21, wherein the dissolvable material is dissolvable by a dissolving fluid selected from a group consisting of benzene, acetone, acids, such as hydrochloric acid, sulphuric acid, phosphoric acid, hydrofluoric acid and
30 similar fluids.

23. A method as claimed in claim 15 or 16, wherein the sleeve is made from an elastically deformable material that is temporarily retainable in an initial cylindrical shape.
- 5 24. A method as claimed in claim 23, wherein the sleeve is retained in the initial cylindrical shape by at least one retaining member.
25. A method as claimed in claim 24, wherein the retaining member is an internal ring.
- 10 26. A method as claimed in claim 25, wherein the sleeve and the ring are retrievable to the surface of the well.
- 15 27. A method of preventing accumulation of unwanted materials comprising:
providing a first string of casing having an enlarged inner diameter portion at an end into a wellbore;
coupling a dissolvable sleeve to the enlarged inner diameter portion; and
dissolving the sleeve with a dissolving solution.
- 20 28. A method of preventing accumulation of unwanted materials comprising:
providing a first string of casing having an enlarged inner diameter portion at an end and a deformable sleeve into a wellbore;
coupling a sleeve to the enlarged inner diameter portion;
expanding the deformable sleeve; and
25 retrieving the sleeve.
- 30 29. A method of preventing accumulation of unwanted materials comprising:
providing a cement shoe assembly having a housing with an enlarged inner diameter portion at an end;
attaching a sleeve to cover the enlarged inner diameter portion; and
expanding the sleeve into the enlarged inner diameter portion.

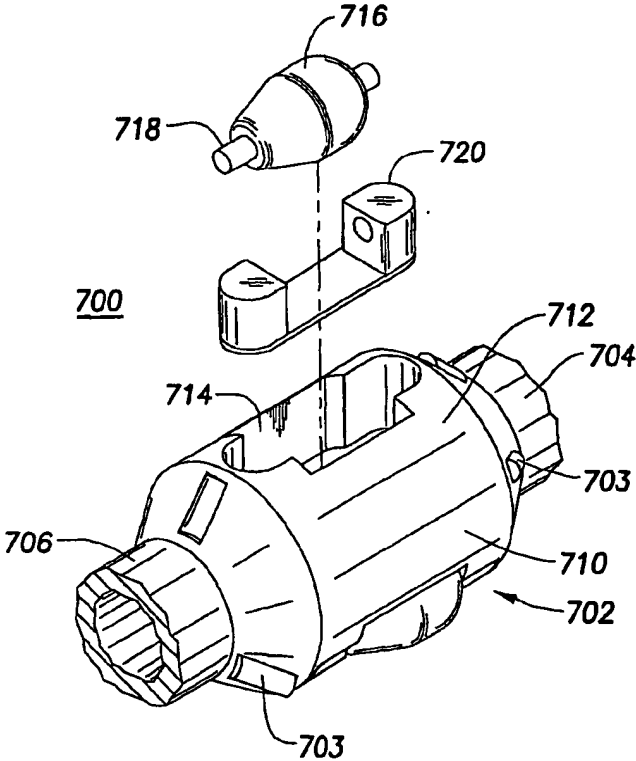

FIG.1

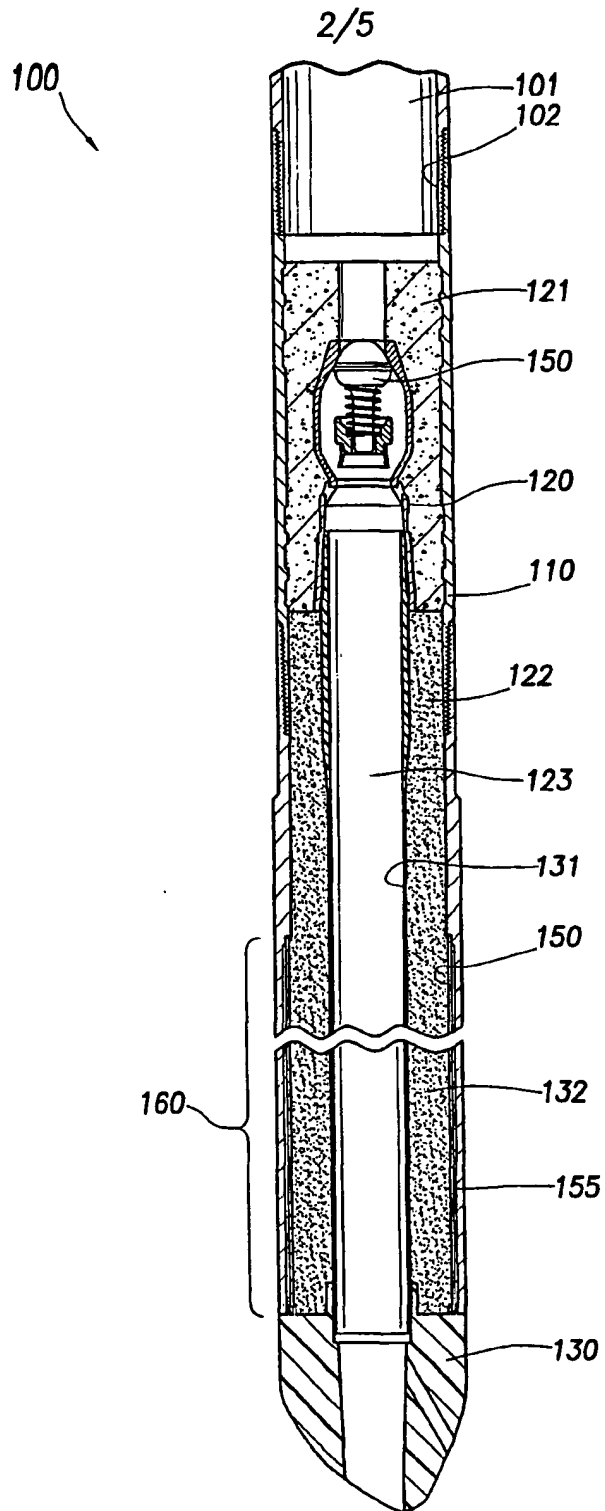

FIG.2

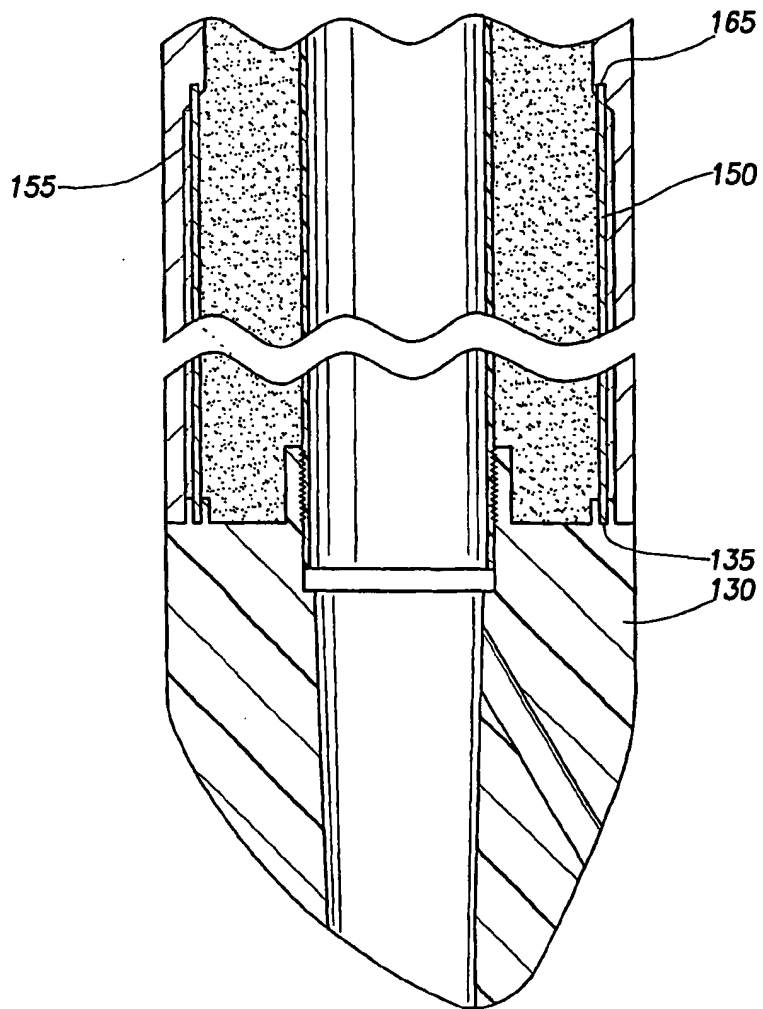

FIG.3

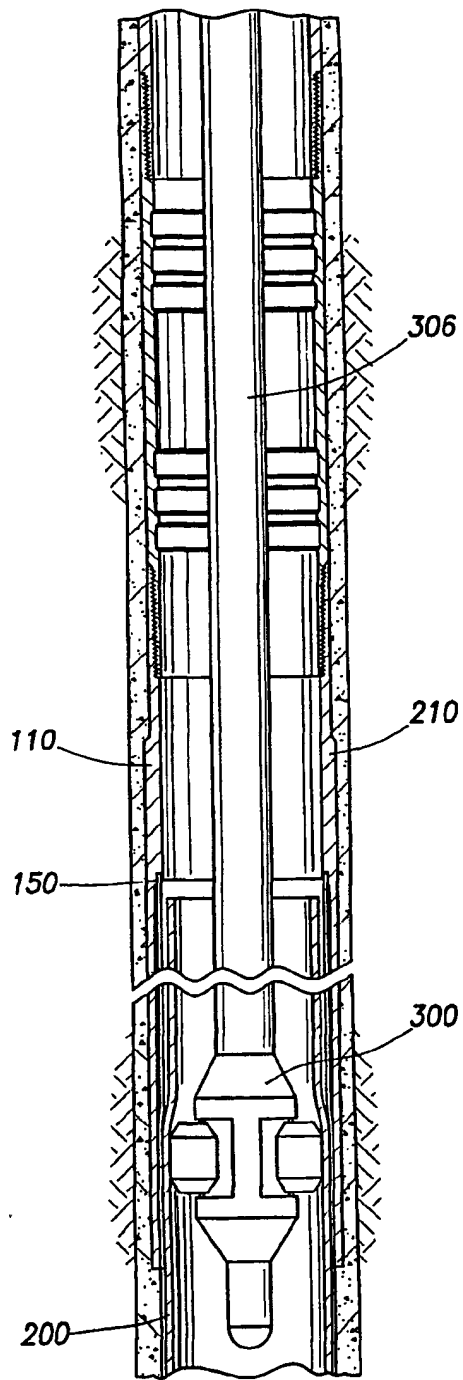

FIG. 4

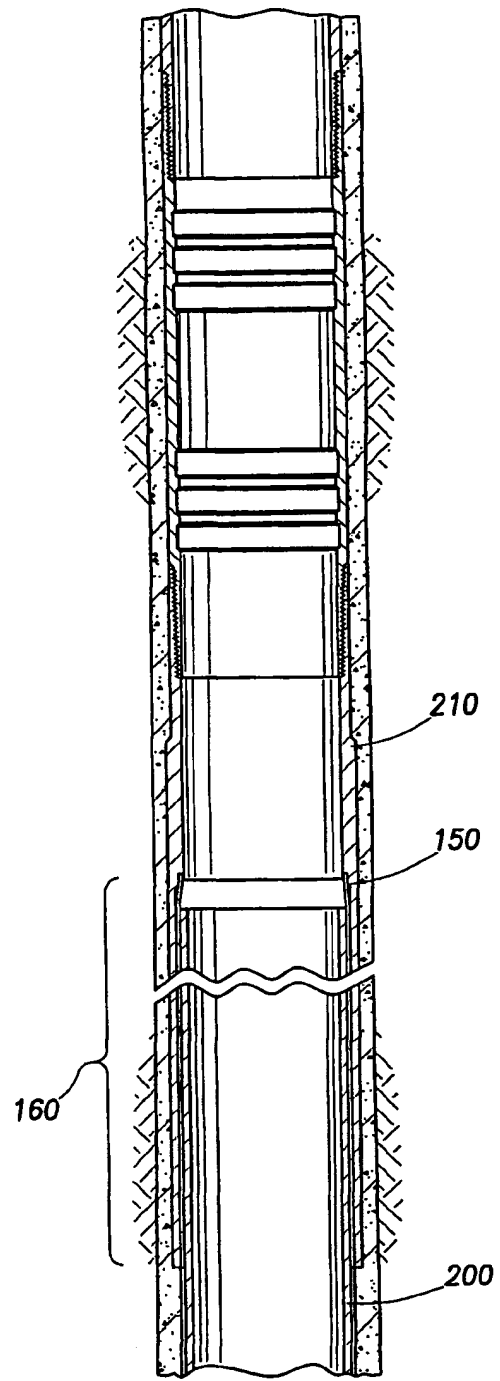

FIG. 5

5/5

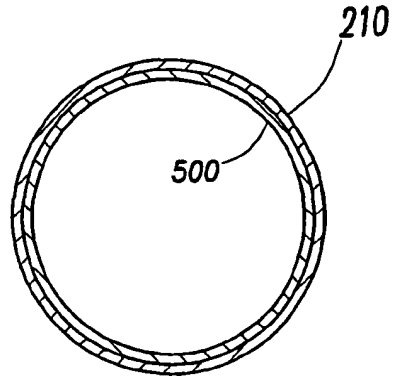

FIG. 6

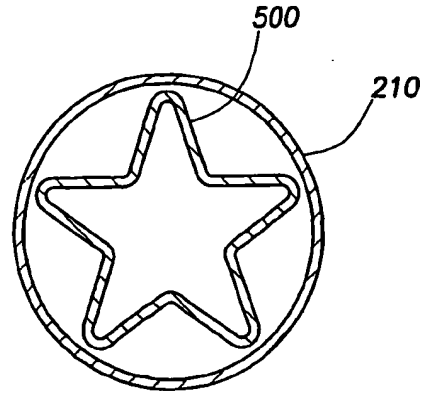

FIG. 7

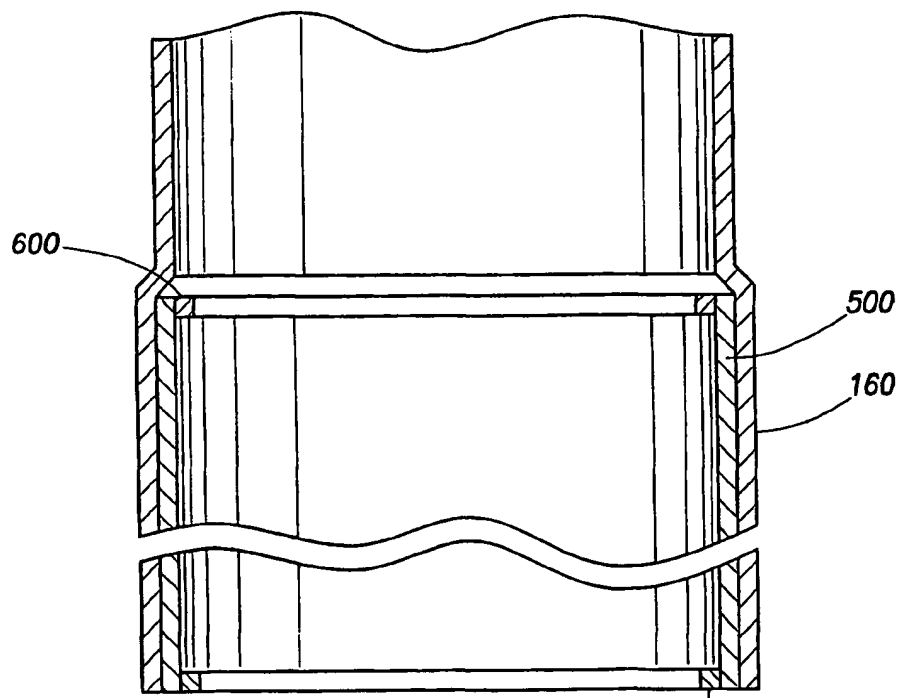

FIG. 8

INTERNATIONAL SEARCH REPORT

onal Application No
PCT/GB 02/02886

A. CLASSIFICATION OF SUBJECT MATTER
IPC 7 E21B43/10

According to International Patent Classification (IPC) or to both national classification and IPC

B. FIELDS SEARCHED

Minimum documentation searched (classification system followed by classification symbols)
IPC 7 E21B

Documentation searched other than minimum documentation to the extent that such documents are included in the fields searched

Electronic data base consulted during the international search (name of data base and, where practical, search terms used)
EPO-Internal

C. DOCUMENTS CONSIDERED TO BE RELEVANT

Category *	Citation of document, with indication, where appropriate, of the relevant passages	Relevant to claim No.
X	WO 01 04535 A (STEWART R BRUCE ;COOK ROBERT LANCE (US); ENVENTURE GLOBAL TECHNOLO) 18 January 2001 (2001-01-18) the whole document see in particular: -fig. 53c -shoes 908,1315,1720,3520,3940 -cpmposition of shoes 3355, 3520	1-22

Further documents are listed in the continuation of box C. Patent family members are listed in annex.

* Special categories of cited documents :

- *A* document defining the general state of the art which is not considered to be of particular relevance
- *E* earlier document but published on or after the international filing date
- *L* document which may throw doubts on priority claim(s) or which is cited to establish the publication date of another citation or other special reason (as specified)
- *O* document referring to an oral disclosure, use, exhibition or other means
- *P* document published prior to the international filing date but later than the priority date claimed
- *T* later document published after the international filing date or priority date and not in conflict with the application but cited to understand the principle or theory underlying the invention
- *X* document of particular relevance; the claimed invention cannot be considered novel or cannot be considered to involve an inventive step when the document is taken alone
- *Y* document of particular relevance; the claimed invention cannot be considered to involve an inventive step when the document is combined with one or more other such documents, such combination being obvious to a person skilled in the art.
- *Z* document member of the same patent family

Date of the actual completion of the international search 24 September 2002	Date of mailing of the international search report 04/10/2002
---	---

Name and mailing address of the ISA European Patent Office, P.B. 5818 Patentlaan 2 NL - 2280 HV Rijswijk Tel. (+31-70) 340-2040, Tx. 31 651 epo nl, Fax: (+31-70) 340-3016	Authorized officer Tompouloglou, C
--	--

INTERNATIONAL SEARCH REPORT
information on patent family members

ional Application No
PCT/GB 02/02886

Patent document cited in search report	Publication date	Patent family member(s)	Publication date
WO 0104535 A	18-01-2001	AU 5921400 A	30-01-2001
		GB 2368865 A	15-05-2002
		NO 20020070 A	08-03-2002
		WO 0104535 A1	18-01-2001
		US 2002060068 A1	23-05-2002